

# Linear Translation Stage

## LAC - 20 - LIE

### Typical applications

- Optical alignment systems
- Measurement and calibration setups
- Precision positioning applications

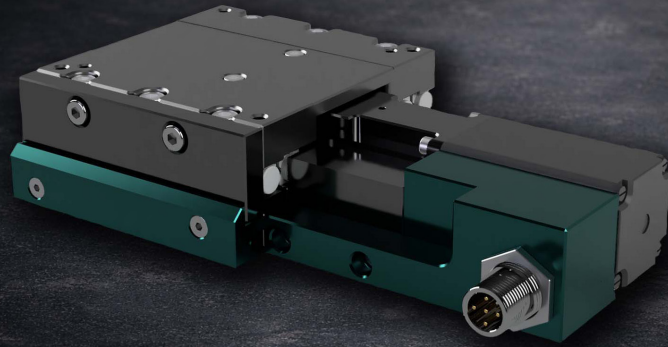

### Product description

LAC-20-LIE is a compact linear translation stage for precise and controlled linear motion. It offers 20 mm travel, a rigid mechanical design and a ballscrew drive for stable and repeatable positioning.

The stage supports both incremental and absolute linear encoders.

### Key features

- Travel range: 20 mm
- Ballscrew-driven linear motion
- Bidirectional positioning with encoder feedback
- Minimum incremental movement: 0.2  $\mu\text{m}$
- Incremental linear encoder as standard
- Absolute linear encoder available as option
- Optical reference switch
- Stepper motor as standard, brushless DC motor optional

### Technical specifications LAC-20-LIE

Dimensions	Unit	Value
L1	mm	166
L2	mm	80
W	mm	92
T	mm	35

Specifications	Unit	Value
Travel	mm	20
Ballscrew Lead	mm	2
Thrust	N	120
Vertical load (on platform)	N	120
Perpendicular load	N	80

All dimensions in mm.

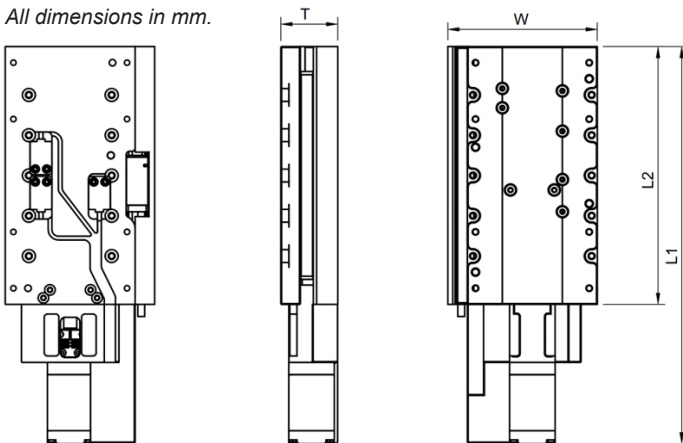

Positioning	Unit	Value
Bidirectional with encoder	$\mu\text{m}$	Encoder resolution
Minimum incremental movement	$\mu\text{m}$	0.2

Accuracy	Unit	Value
Pitch	$\mu\text{rad}$	100
Yaw	$\mu\text{rad}$	100

Encoder	Unit	Value
Incremental linear		X
Absolute linear		option
Resolution	$\mu\text{m}$	0.5, 0.2, 0.1
Reference switch		optical

Motor	Unit	Value
Type		Stepper brushless DC optional

Stepper motor specifications	Unit	Value
Nema		11
Current per winding	A	1.4
Inductance	mH	1.8
Resistance	Ohm	2.3
Resolution	deg/full step	1.8

Specifications are subject to change without notice.

**Interested in this product?**  
Contact us for drawings,  
datasheets or custom adaptations.

www.heftytec.com  
info@heftytec.com  
Document version: v1.0 – 2026



# Linear Translation Stage

## LAC - 104 - LIE

### Typical applications

- Optical alignment systems
- Measurement and calibration setups
- Precision positioning over extended travel ranges



### Product description

LAC-104-LIE is a compact linear translation stage for precise and controlled linear motion. It offers 104 mm travel, a rigid mechanical design and a ballscrew drive for stable and repeatable positioning.

The stage supports both incremental and absolute linear encoders.

### Technical specifications LAC-104-LIE

Dimensions	Unit	Value
L1	mm	246.5
L2	mm	160
W	mm	92
T	mm	35

Specifications	Unit	Value
Travel	mm	104
Ballscrew lead	mm	2
Thrust	N	120
Vertical load (on platform)	N	220
Perpendicular load	N	150

All dimensions in mm.

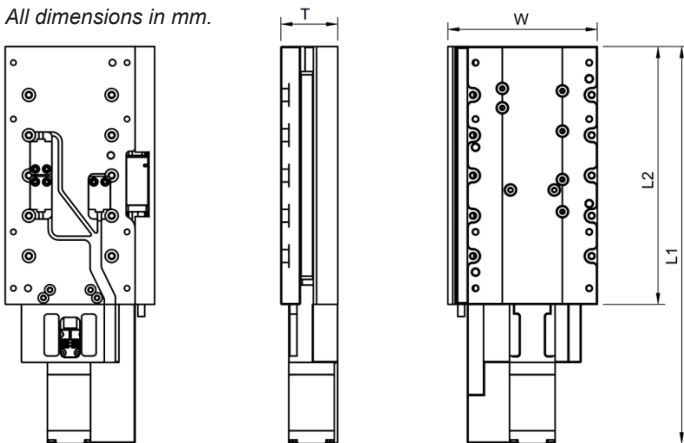

### Key features

- Travel range: 104 mm
- Ballscrew-driven linear motion
- Bidirectional positioning with encoder feedback
- Minimum incremental movement: 0.2  $\mu\text{m}$
- Incremental linear encoder as standard
- Absolute linear encoder available as option
- Optical reference switch
- Stepper motor as standard, brushless DC motor optional

Positioning	Unit	Value
Bidirectional with encoder	$\mu\text{m}$	Encoder resolution
Minimum incremental movement	$\mu\text{m}$	0.2

Accuracy	Unit	Value
Pitch	$\mu\text{rad}$	100
Yaw	$\mu\text{rad}$	100

Encoder	Unit	Value
Incremental linear		X
Absolute linear		option
Resolution	$\mu\text{m}$	0.5, 0.2, 0.1
Reference switch		optical

Motor	Unit	Value
Type		Stepper brushless DC optional

Stepper motor specifications	Unit	Value
Nema		11
Current per winding	A	1.4
Inductance	mH	1.8
Resistance	Ohm	2.3
Resolution	deg/full step	1.8

Specifications are subject to change without notice.

**Interested in this product?**  
Contact us for drawings,  
datasheets or custom adaptations.

www.heftytec.com  
info@heftytec.com  
Document version: v1.0 – 2026



# Linear Translation Stage

## LAC - 158 - LIE

### Typical applications

- Optical alignment systems
- Measurement and calibration setups
- Precision positioning for larger setups and longer travel applications

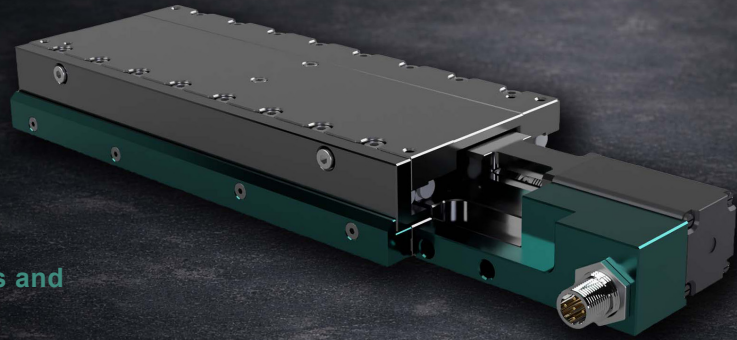

### Product description

LAC-158-LIE is a compact linear translation stage designed for precise and controlled linear motion. It offers a travel range of 158 mm and a rigid mechanical design with a ballscrew drive, making it suitable for applications requiring stable positioning and repeatability over longer travel distances.

The stage supports both incremental and absolute linear encoders.

### Key features

- Travel range: 158 mm
- Ballscrew-driven linear motion
- Bidirectional positioning with encoder feedback
- Minimum incremental movement: 0.2  $\mu\text{m}$
- Incremental linear encoder as standard
- Absolute linear encoder available as option
- Optical reference switch
- Stepper motor as standard, brushless DC motor optional

### Technical specifications LAC-158-LIE

Dimensions	Unit	Value
L1	mm	310
L2	mm	214
W	mm	92
T	mm	35

Specifications	Unit	Value
Travel	mm	158
Ballscrew lead	mm	2
Thrust	N	120
Vertical load (on platform)	N	320
Perpendicular load	N	180

All dimensions in mm.

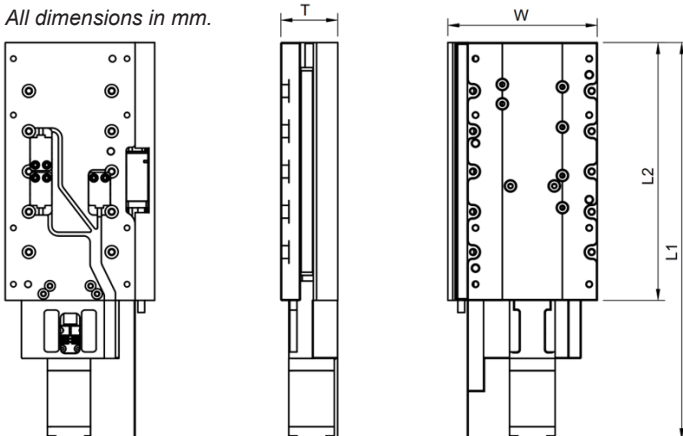

Positioning	Unit	Value
Bidirectional with encoder	$\mu\text{m}$	Encoder resolution
Minimum incremental movement	$\mu\text{m}$	0.2

Accuracy	Unit	Value
Pitch	$\mu\text{rad}$	100
Yaw	$\mu\text{rad}$	100

Encoder	Unit	Value
Incremental linear encoder	–	Yes
Absolute linear encoder	–	Option
Encoder resolution	$\mu\text{m}$	0.5 / 0.2 / 0.1
Reference switch	–	Optical

Motor	Unit	Value
Type		Stepper brushless DC optional

Stepper motor specifications	Unit	Value
Nema		11
Current per winding	A	1.4
Inductance	mH	1.8
Resistance	Ohm	2.3
Resolution	deg/full step	1.8

Specifications are subject to change without notice.

**Interested in this product?**  
Contact us for drawings,  
datasheets or custom adaptations.

www.heftytec.com  
info@heftytec.com  
Document version: v1.0 – 2026

